

ACCU ELECTRIC MOTORS INC

USA: (888) 932-9183

CANADA: (905) 829-2505

- ✓ Over 100 years cumulative experience
- ✓ 24 hour rush turnaround / technical support service
- ✓ Established in 1993



The leading independent repairer of servo motors and drives in North America.

Visit us on the web:

www.servo-repair.com

www.servorepair.ca

www.ferrocontrol.com

www.sandvikrepair.com

www.accuelectric.com

Scroll down to view your document!

For 24/7 repair services :

USA: 1 (888) 932 - 9183

Canada: 1 (905) 829 -2505

Emergency After hours: 1 (416) 624 0386

Servicing USA and Canada

COMBIVERT



GB INSTRUCTION MANUAL

Control Circuit from V3.2



This Instruction Manual describes the control circuit of the KEB COMBIVERT F5 - Series. It is only valid together with the Instruction Manuals Part 1 and Part 2. Both Instruction Manuals must be made available to the user. Prior to performing any work on the unit the user must familiarize himself with the unit. This includes especially the knowledge and observance of the safety and warning directions of Part 1. The pictographs used in this instruction manual have following meaning:

GB - 3.....GB - 34



Danger
Warning
Caution



Attention
observe at
all costs



Information
Help
Tip

- 1. Intended use 4**
- 2. Installation and Connection 5**
 - 2.1 Summary 5**
 - 2.1.1 Housing Size D - E 5
 - 2.1.2 Housing Size >= G..... 5
 - 2.2 Control board Servo 6**
 - 2.2.1 Assignment of Terminal Strip X2A 6
 - 2.2.2 Connection of the control circuit 7
 - 2.2.3 Digital Inputs 7
 - 2.2.4 Analog Inputs..... 7
 - 2.2.5 Voltage Input / External Power Supply 8
 - 2.2.6 Digital Outputs 8
 - 2.2.7 Relay Outputs 8
 - 2.2.8 Analog Outputs 8
 - 2.2.9 Voltage Output 8
 - 2.2.10 Motor connection 9
 - 2.2.11 Resolver connection X3A..... 10
 - 2.2.12 incremental encoder simulation X3B 10
 - 2.2.13 Cable 11
 - 2.3 Operator..... 12**
- 3. Operation of the Unit..... 13**
 - 3.1 Keyboard 13**
 - 3.2 Parameter Summary 14**
 - 3.2.1 Password Input 15
 - 3.2.2 Operating Display 15
 - 3.2.4 Special Adjustments 20
 - 3.3 Motor data (factory setting) 26**
 - 3.4 The drive mode 27**
 - 3.4.1 Start/stop drive..... 27
 - 3.4.2 Changing the direction of rotation..... 27
 - 3.4.3 Presetting the setpoint 27
 - 3.4.4 Leaving the drive mode 27
- 4. Error Assistance 28**
- 5. Initial Start-up 34**
- 6. Adjustment Speed Controller..... 35**
- 7. Quick Reference 36**
- 8. Passwords..... 39**

1. **Intended use**

The digital servo controller KEB COMBIVERT F5-SERVO serves exclusively for the control and regulation of the servo motors KEB COMBIVERT SM.

On delivery the controllers are tuned to the servo motors supplied by KEB. So you receive a highly dynamic drive which is connected and ready for operation within the shortest time for standard applications.

The operation of other motors requires an adaption of the amplifier and is to be recommended only with special knowledge of control technology.

KEB COMBIVERT F5-SERVO has very extensive programming options. To make the operation and start-up simpler for the user, a special operator level was created in which the most important parameters are found. However, if the parameters pre-defined by KEB are not sufficient for your application an application manual is available.

2. Installation and Connection

2.1 Summary

2.1.1 Housing Size D - E

<p>Optional Operator with 9-pole Sub-D Socket Parameter Interface</p>	
<p>X2A Connection Connection of control terminal</p>	
<p>X3B 9-pole Sub-D Socket Incremental encoder simulation</p>	
<p>X3A 15-pole Sub-D Socket Closed-loop resolver system</p>	

2.1.2 Housing Size >= G

<p>Optional Operator with 9-pole Sub-D Socket Parameter Interface</p>		
<p>X3A 15-pole Sub-D Socket Closed-loop resolver system</p>		
<p>X3B 9-pole Sub-D Socket Incremental encoder simulation</p>		
<p>X2A Connection Connection of control terminal</p>		
	<p>Observe the maximal width of connectors for X3A and X3B</p>	

GB

2.2 Control board Servo

X2A

2.2.1 Assignment of Terminal Strip X2A



PIN	Function	Name	Description
Analog inputs			
1	+ Set value input 1	AN1+	0...±10 VDC ^ 0...±CP.22 Resolution 12 Bit Scan time 1 ms
2	- Set value input 1	AN1-	
3	+ Analog input 2	AN2+	
4	- Analog input 2	AN1-	
Analog outputs			
5	Analog output 1	ANOUT1	Analog output of the real speed 0...±10 VDC ^ 0...±3000 rpm
6	Analog output 2	ANOUT2	Analog output of the apparent current 0...10 VDC ^ 0...2 x IN
5 mA; Ri=100 Ω Resolution 12 Bit PWM frequency 3,4kHz Limiting frequency Filter 1. Harmonic 178Hz			
Voltage supply			
7	+10 V Output	CRF	Reference voltage for setpoint potentiometer
8	Analog Mass	COM	Mass for analog in- and outputs
9			
Digital inputs			
10	Fixed Speed 1	I1	I1+I2 = fixed speed 3 (default: 0 rpm) no input = analog set value 13...30VDC ±0% stabilized Ri=2,1 kΩ Scan time 1 ms
11	Fixed speed 2	I2	
12	External fault	I3	
13	-	I4	
14	Limit switch forward	F	
15	Limit switch reverse	R	
16	Control release / Reset	ST	
17	reset	RST	Reset; only when an error occurs
Transistor outputs			
18	Speed dependent	O1	Transistor output switched at actual speed = set speed
19	Ready signal	O2	Transistor output switched, as long as no error occurs
Voltage supply			
20	24 V-Output	Uout	Approx. 24V output (max.100 mA))
21	20...30V-Input	Uin	Voltage input for external supply
22	Digital Mass	0V	Potential for digital in-/outputs
23			
Relay Outputs			
24	NO contact 1	RLA	Fault relay (default); Function can be changed with CP.33 at maximum 30VDC 0.01...1A
25	NC contact 1	RLB	
26	Switching contact 1	RLC	
27	NO contact 2	FLA	Run-Signal (default); Function can be changed with CP.34
28	NC contact 2	FLB	
29	Switching contact 2	FLC	
		1) The reaction can be adjusted with CP.35 and CP. 36.. If the unit is defective there is no guarantee that the software protective function will work.	

2.2.2 Connection of the control circuit

In order to prevent a malfunction caused by interference voltage supply on the control inputs, the following directions should be observed:



- Use shielded / drilled cables
- Lay shield on one side of the inverter onto earth potential
- Lay control and power cable separately (about 10...20 cm apart); Lay crossings in a right angle (in case it cannot be prevented)

2.2.3 Digital Inputs

Using of the internal voltage supply

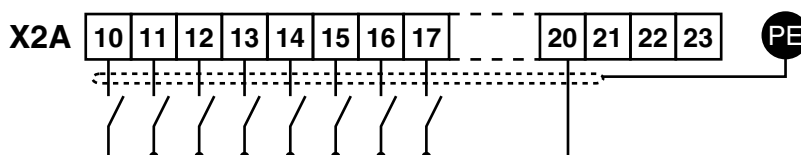

Using of an external voltage supply

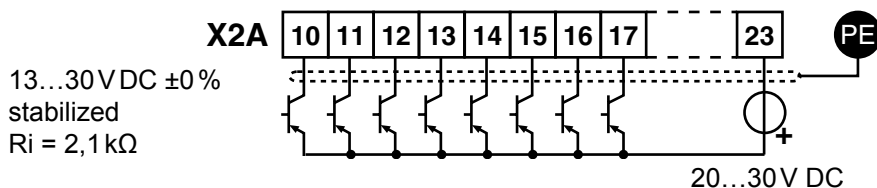

2.2.4 Analog Inputs

Connect unused analog inputs to common, to prevent set value fluctuations!

Analog set value setting in speed regulated operation (CP.10 = 4):

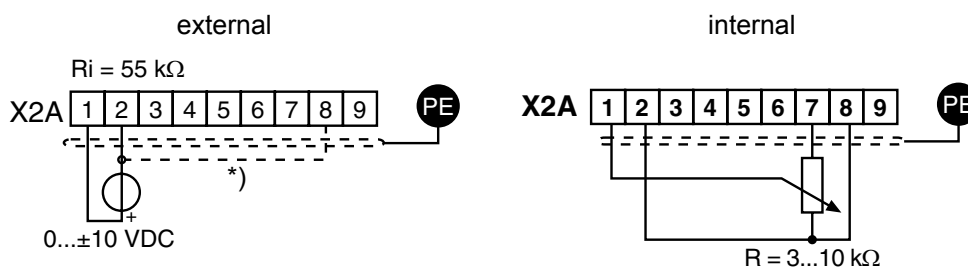

Analog set value setting in torque regulated operation (CP.10 = 5) and reference source CP.28 = 1:

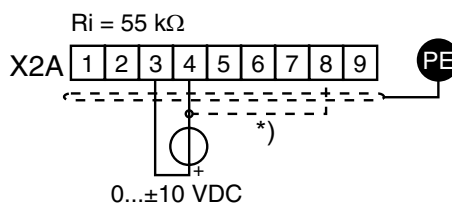

- *) Connect potential equalizing line only if a potential difference of >30 V exists between the controls. The internal resistance is reduced to 30 kΩ.

2.2.5 Voltage Input / External Power Supply

The supply of the control circuit through an external voltage source keeps the control in operational condition even if the power stage is switched off. To prevent undefined conditions at external power supply the basic procedure is to first switch on the power supply and after that the inverter.

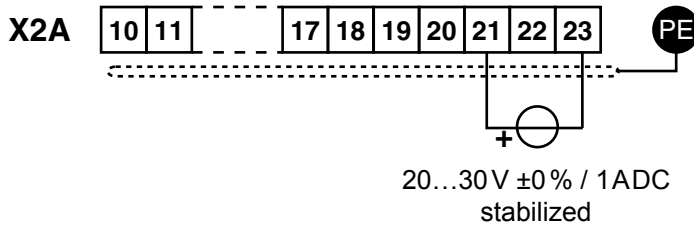

2.2.6 Digital Outputs

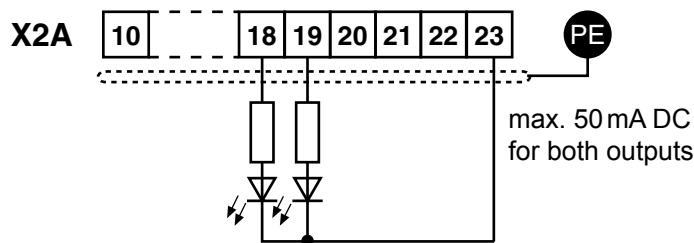

2.2.7 Relay Outputs

In case of inductive load on the relay outputs a protective wiring must be provided (e.g. free-wheeling diode)!

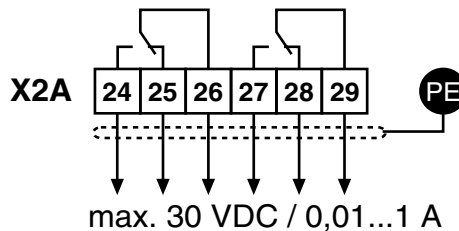

2.2.8 Analog Outputs

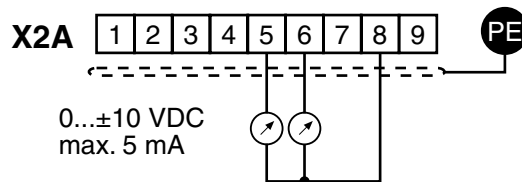

2.2.9 Voltage Output

The voltage output serves for the setting of the digital inputs as well as for the supply of external control elements. Do not exceed the maximum output current of 100 mA.

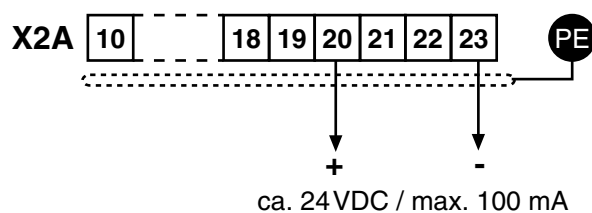

2.2.10 Motor connection

	The power connector may only be connected / disconnected when the device and the power supply are disconnected!
	Observe correct phase sequence of the servo motor!

GB

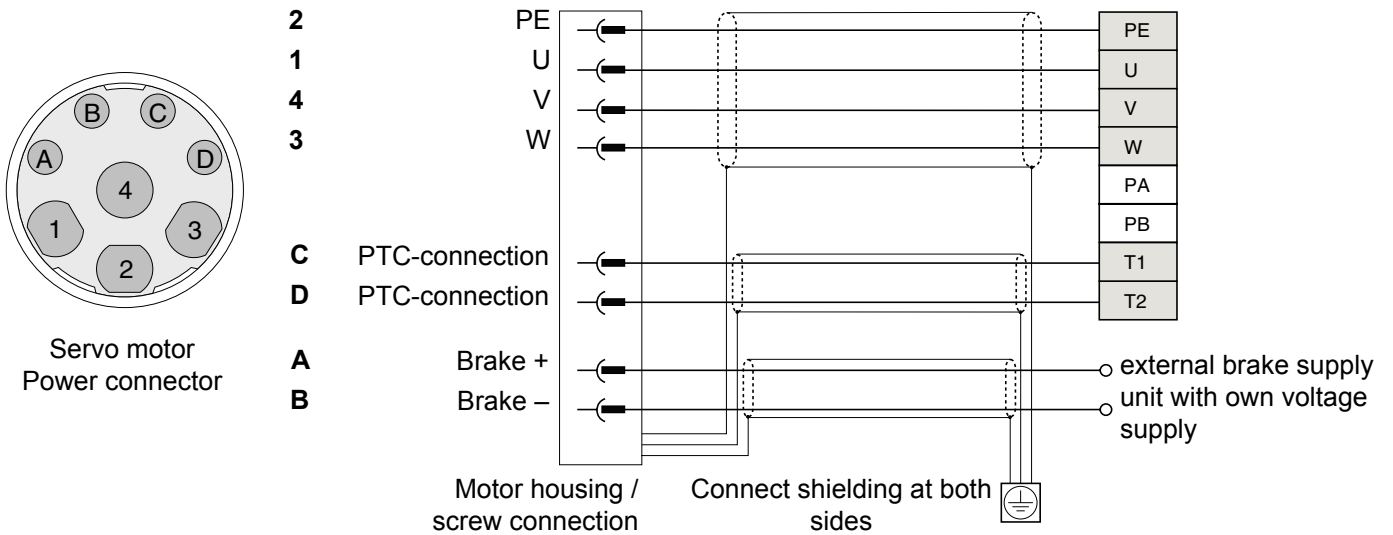

Connector Pin No.	Name	Cable Core No.
1	U	1
4	V	2
3	W	3
2	PE	green-yellow
A	Brake +	5
B	Brake -	6
C	PTC-Contact	7
D	PTC-Contact	8

Installation and Connection

2.2.11 Resolver connection X3A

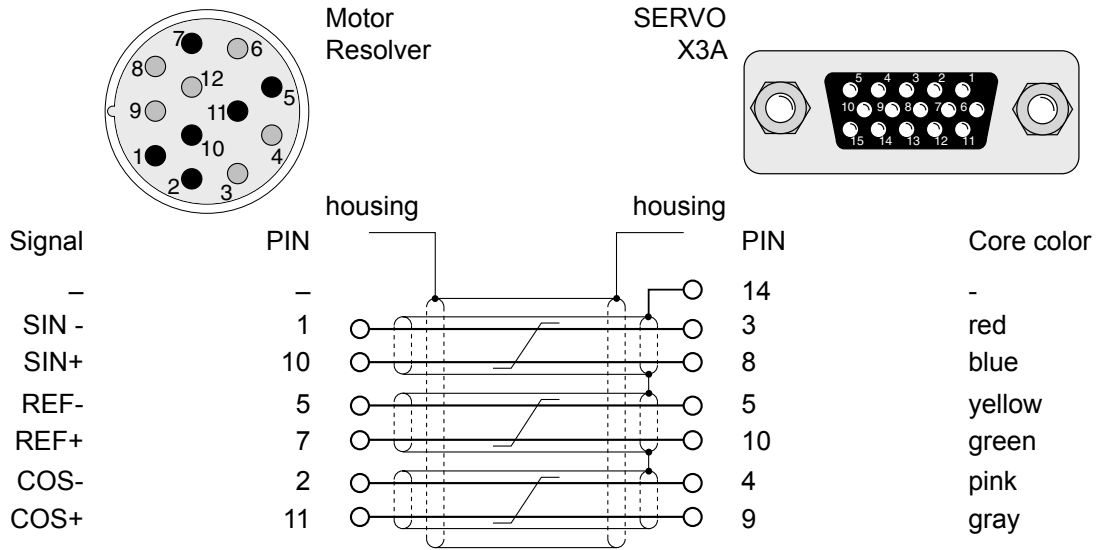

2.2.12 incremental encoder simulation X3B

The increments of the emulation are fixed to 1024 for units with resolver interface. The 20...30 V voltage supply at X3A and X3B is loadable with altogether 170 mA. If higher voltages / currents are needed for the supply of the incremental encoder, then the control must be supplied with an external voltage.

The +5 V voltage is a stabilized voltage, which at X3A and X3B is loadable with altogether 500 mA. Since the +5,2 V are generated from Uvar, the current from Uvar decreases in accordance with following formula:

$$I_{var} = 170\text{mA} - \frac{5,2\text{V} \cdot I+5\text{V}}{U_{var}}$$

X3B		PIN No.	Signal
		1	A+
		2	B+
		3	N+
		4	+5,2V
		5	Uvar 20...30 V ¹⁾
		6	A-
		7	B-
		8	N-
		9	GND
			¹⁾ depending on power circuit

The tracks A+/A-, B+/B- and N+/N- must be fitted with a terminating resistor of approx. 150 Ω!



The plug may only be connected / disconnected when the inverter and supply voltage are disconnected!

2.2.13 Cable

For the servo system KEB COMBIVERT F5-SERVO factory-assembled motor and resolver cables are available in the lengths 5 m, 10 m, 15 m and 20 m.

00.S4	019	-	0005	
			Cable length	0005 = 5 m
				0010 = 10 m
				0015 = 15 m
				0020 = 20 m
			Part	019 = Motor cable 1,5 mm ²
				119 = Motor cable 2,5 mm ²
			Type designation	

00.F5	0C1	-	1005	
			Cable length	1005 = 5 m
				1010 = 10 m
				1015 = 15 m
				1020 = 20 m
			Part	0C1 = Resolver cable
			Type designation	

	Max. Encoder cable length 50 m. Longer encoder cables on request.
--	--

GB

Installation and Connection

2.3 Operator

As an accessory to the local or external (option: cable 00.F5.0C0-1xxx) operation an operator is necessary. To prevent malfunctions, the inverter must be brought into nOP status before connecting / disconnecting the operator (open control release terminal). When starting the inverter, it is started with the last stored values or factory setting.

GB

Digital operator (part number 00.F5.060-1000)		Interface operator (part number 00.F5.060-2000)	
x	x	5-digit LED Display	
x	x	Operating-/Error display Normal "LED on" Error "LED blinks"	
-	x	Interface control Transmit "LED on"	
x	x	Double function keyboard	
-	x	X6B HSP5 programming and diagnostic interface	
-	x	X6C RS232/RS485	



Only use the operator interface for the serial data transfer to RS232/485. The direct connection, PC to the inverter is only valid with a special cable (part number 00.F5.0C0-0001), otherwise, it would lead to the destruction of the PC-interface!

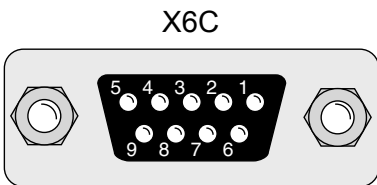

PIN	RS485	Signal	Meaning
1	-	-	reserved
2	-	TxD	transmission signal RS232
3	-	RxD	receive signal RS232
4	A'	RxD-A	receive signal A RS485
5	B'	RxD-B	receive signal B RS485
6	-	VP	Voltage supply +5V (I _{max} =10 mA)
7	C/C'	DGND	Data reference potential
8	A	TxD-A	transmission signal A RS485
9	B	TxD-B	transmission signal B RS485

RS 232 cable
Part number
00.58.025-001D
Length 3m

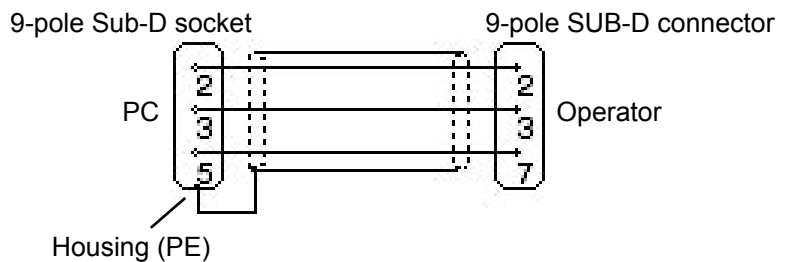

3. Operation of the Unit

3.1 Keyboard

When switching on KEB COMBIVERT F5 the value of parameter CP.1 appears (see Drive mode to switch the keyboard function).

The function key (FUNC) changes between the parameter value and parameter number.



GB

With UP (▲) and DOWN (▼) the value of the parameter number is increased/decreased with changeable parameters.



Principally during a change, parameter values are immediately accepted and stored non-volatile. However, with some parameters it is not useful that the adjusted value is accepted immediately. In these cases (CP.28, CP.32, CP.33, CP.34) the adjusted value is accepted and stored non-volatile by pressing ENTER.

If a malfunction occurs during operation, then the actual display is overwritten by the alarm message. The alarm message in the display is reset by ENTER.

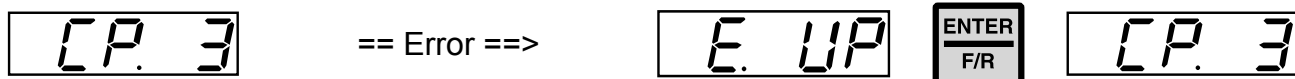

With ENTER only the error message in the display is reset. In the inverter status display (CP.3) the error is still displayed. In order to reset the error itself, the cause must be removed or a power-on reset must be made.

3.2 Parameter Summary

Displ.	Parameter	Setting range	Resolution	Default	Unit	↕	Based on
CP.00	Password Input	0...9999	1	-	-	-	ud.1
CP.01	Encoder 1 speed	±4000	0.125	0	rpm	-	ru.9
CP.02	Setpoint display	±4000	0.125	0	rpm	-	ru.1
CP.03	Inverter state	0...255	1	0	-	-	ru.0
CP.04	Apparent current	0...6553.5	0.1	0	A	-	ru.15
CP.05	Peak apparent current	0...6553.5	0.1	0	A	-	ru.16
CP.06	Actual torque	±10000.00	0.01	0	Nm	-	ru.12
CP.07	Actual DC voltage	0...1000	1	0	V	-	ru.18
CP.08	Peak DC voltage	0...1000	1	0	V	-	ru.19
CP.09	Output voltage	0...778	1	0	V	-	ru.20
CP.10	Speed control configuration	4...5	1	0	-	-	cs.0
CP.11	DSM rated torque	0,1...6553,5	0.1	LTK	Nm	-	dr.27
CP.12	DSM rated speed	0...32000	1	LTK	rpm	-	dr.24
CP.13	DSM rated frequency	0,0...1600,0	0.1	LTK	Hz	-	dr.25
CP.14	DSM rated current	0,0...710,0	0.1	LTK	A	-	dr.23
CP.15	DSM EMK	0...1000	1	LTK	V	-	dr.26
CP.16	DSM winding inductance	0,01...500,00	0.01	LTK	mH	-	dr.31
CP.17	DSM winding resistance	0,000...50,000	0.001	LTK	Ohm	-	dr.30
CP.18	DSM current for zero speed	0,0...700,0	0.1	LTK	A	-	dr.28
CP.19	Load motor dependent parameter	1...2	1	1	-	E	fr.10
CP.20	System position	0...65535	1	57057	-	-	ec.2
CP.21	Rotation change	0...19	1	0	-	-	ec.6
CP.22	Maximum speed	0...4000	0.125	2100	rpm	-	op.10
CP.23	Fixed Speed 1	±4000	0.125	100	rpm	-	op.21
CP.24	Fixed speed 2	±4000	0.125	-100	rpm	-	op.22
CP.25	Acceleration time	0.00...300.00	0.01	5,00	s	-	op.28
CP.26	Deceleration time	-0.01...300.00	0.01	5,00	s	-	op.30
CP.27	S-curve time	0.00...5.00	0.01	0,00	s	-	op.32
CP.28	Torque reference source	0...5	1	2	-	E	cs.15
CP.29	Absolute torque reference	±10000.00	0.01	LTK	Nm	-	cs.19
CP.30	KP speed	0...32767	1	300	-	-	cs.6
CP.31	KI speed	0...32767	1	100	-	-	cs.9
CP.32	Switching frequency	2/4/8/12/16	-	LTK	kHz	E	uf.11
CP.33	Relay output 1 / Function	0...84	1	4	-	E	do.2
CP.34	Relay output 2 / Function	0...84	1	2	-	E	do.3
CP.35	Reaction to limit switch	0...6	1	6	-	-	pn.7
CP.36	Response of external fault	0...6	1	0	-	-	pn.3

LTK) depending on power circuit or on size (see 3.7 „Standard motor data“)



Due to the calculation / measuring accuracies, tolerances with the current and torque displays as well as with the switching levels and limitations, must be taken into consideration.
Dependent on the data from the motor manufacturer, larger tolerances at the torque displays are possible, due to the usual variations in the machine parameters and temperature drifts.

3.2.1 Password Input

CP.00 Password Input

Ex works the frequency inverter is supplied without password protection, this means that all changeable parameters can be adjusted. After parameterizing the unit can be barred against unauthorized access (Passwords: see last but one page). The adjusted mode is stored.

GB

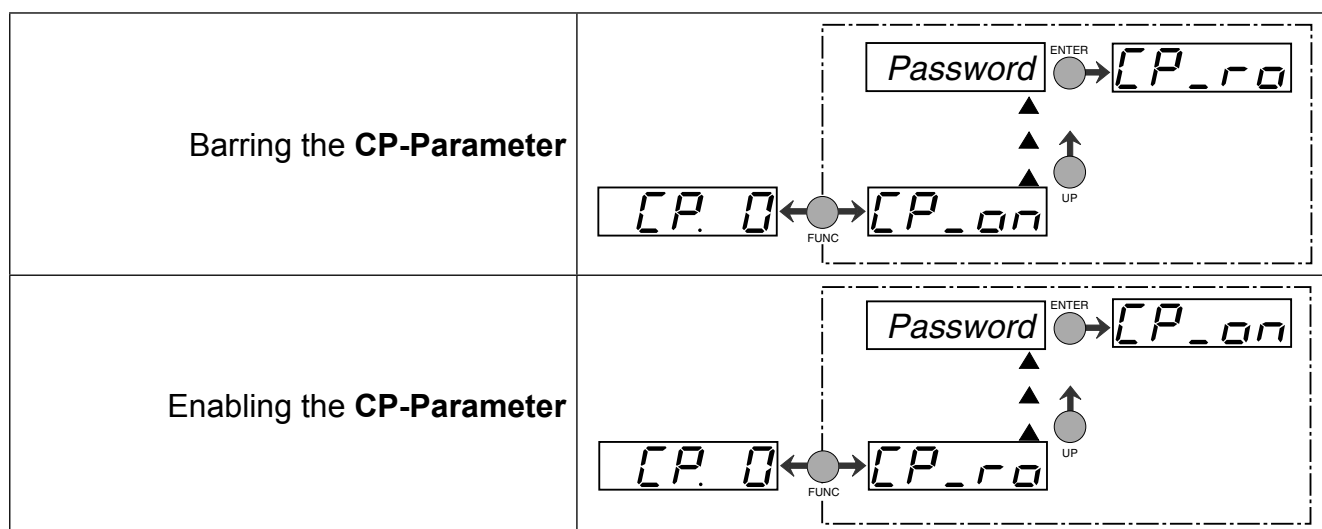

3.2.2 Operating Display

The parameters below serve for the controlling of the frequency inverter during operation.

CP.01 Encoder 1 speed

Co-domain	Description
0...±4000 rpm	Display of actual motor speed (incremental encoder 1). For control reasons the set speed is displayed, even if the control release or direction of rotation are not switched. A counter-clockwise rotating field (reverse) is represented by a negative sign. Precondition for the correct display value is the in-phase connection of the motor and the correct setting of the encoder line number (CP.20) as well as the direction of rotation (CP.21).

CP.02 Setpoint display

Co-domain	Description
0...±4000 rpm	Display of actually set value. For control reasons the set speed is displayed, even if the control release or direction of rotation are not switched. If no direction of rotation is set, the set speed for clockwise rotation (forward) is displayed.





CP.03 Inverter status

The status display shows the actual working conditions of the inverter. Possible displays and their meanings are:

nop	„no Operation“ control release not bridged; modulation switched off; output voltage = 0V; drive is not controlled.
LS	„Low Speed“ no direction of rotation preset; modulation switched off; output voltage = 0V; drive is not controlled.
FAcc	"Forward Acceleration" drive accelerates with direction of rotation forward.
	further on next side

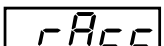
Operation of the Unit

GB

	„Forward Deceleration“ drive decelerates with direction of rotation forward.
	"Reverse Acceleration" drive accelerates with direction of rotation reverse.
	"Reverse Deceleration" drive decelerates with direction of rotation reverse.
	"Forward Constant" drive runs with a constant speed and direction of rotation forward.
	"Reverse Constant" drive runs with constant speed and direction of rotation reverse.

Other status messages are described at the parameters, where they occur (see chapter 4 „Error diagnosis“).

CP.04 Apparent current

Co-domain	Description
0...±6553.5A	Display of the actual apparent current in ampere.

CP.05 Apparent current / peak value

Co-domain	Description
0...±6553.5A	CP.5 makes it possible to recognize the max. apparent current. For that the highest value of CP.4 is stored in CP.5. The peak value memory can be cleared by pressing the UP, DOWN or ENTER key or over bus by writing any value you like to the address of CP.5. The switch off of the inverter also clears the memory.

CP.06 Actual torque

Co-domain	Description
0.0...±10000.00A	The displayed value corresponds to the actual motor torque in Nm. The value is calculated from the active current. Because of normal type differences and temperature deviations of the motors, tolerances of up to 30 % are possible in the base speed range (see reference at 3.2). Requirement for the torque display is the adjustment of the motor data (CP.11...CP.16). If the real motor data deviate strongly from the data on the name plate the operating performance can be optimized by entering the real data. The adjustment of the name plate data is sufficient for a start-up.

CP.07 Intermediate circuit voltage

Display	Description			
0...1000 V	Display of actual DC-link voltage in volt. Typical values:			
	V-class	Normal operation	Overvoltage (E.OP)	Undervoltage (E.UP)
	230 V	300...330 V DC	approx. 400 V DC	approx. 216 V DC
400 V	530...620 V DC	approx. 800 V DC	approx. 240 V DC	

CP.08 DC-link voltage / peak value

Display	Description
0...1000 V	CP.8 makes it possible to recognize short-time voltage rises within an operating cycle. For that the highest value of CP.7 is stored in CP.8. The peak value memory can be cleared by pressing the UP, DOWN or ENTER key or over bus by writing any value you like to the address of CP.8. The switch off of the inverter also clears the memory.

CP.09 Output voltage

Co-domain	Description
0...778V	Display of the actual output voltage in volt.

3.2.3 Basic Adjustment of the Drive

The following parameters determine the fundamental operating data of the drive and must be adjusted for the initial commissioning (see chapter 5 "Start-up"). They should be checked and/or adapted to the application.

CP.10 Speed control configuration

Input	Setting	Function	Description
4	x	Speed control (closed loop operation)	With this parameter the basic setting of the speed controller is determined.
5		Torque control (closed loop operation)	

CP.11...CP.18 Motor data

Under these parameters the motor data can be read off and adjusted. If you have purchased the servo controller with motor from KEB, the optimal motor data are already adjusted and do not need to be changed anymore. The parameter data can be taken from the parameter survey.

CP.19 Load motor dependent parameter

Ex factory the frequency inverter is adapted to the supplied motor (see chapter 3.3). If the motor data in CP.11...18 are changed, then CP.19 must be activated once. This re-adjusts the current controller, torque curve and torque limit. With this, the torque limit is set at the value, that is maximally possible in the speed range (depending on inverter rated current), but not above the rated motor torque x 3.

Co-domain	Setting	Description
1	x	Pre-adjustment of the motor-dependent control-parameters. The voltage class of the inverter is taken as input voltage.
2		Pre-adjustment of the motor-dependent control-parameters. The measured DC-link voltage divided by $\sqrt{2}$ measured at switch on is taken as input voltage. Thus the frequency inverter can be adapted to the actually available mains voltage (e.g. USA with 460 V).
		When control release is active the adjustment was not completed. „nco“ appears in the display.

CP.20 System position

The system position of the attached resolver system is adjusted at this parameter (factory setting). With this parameter it is possible to adjust the controller to a not aligned motor. If the system position of the motor is unknown an automatic trimming can be done.

Before starting with the trimming, the direction of rotation must be checked. The speed display at CP.1 must be positive when the engine runs manual in clockwise direction. If that is not the case, the direction of rotation can be exchanged as described with CP.21. If the correct direction of rotation is displayed, it can be started with the adjustment:

- the connected motor must be able to rotate freely
- open control release (terminal X2A.16)
- set CP.20 = 2206
- close control release (terminal X2A.16)

Now the motor is excited with its rated current and aligned to its zero position. The adjustment is finished when the displayed system position at CP.20 does not change for approx. 5s. In this case open control release and switch off the unit.

If the error message E.EnC is displayed during trimming the direction of rotation must be checked (CP.21). In this case the position trimming must be repeated.

In case that motors with aligned encoder system are used, the value which has been established by the automatic trimming, can be entered under CP.20 as well. The adjustment values of known motors of the KEB COMBIVERT S4 series must be multiplied by the pole-pair number of the motor.

Setting range	Description
0...65535	The input value is a decimal value. The factory setting is 0.

Example 1:

6-pole motor (3 pole pairs) has a system position of 19.019 dec. with a S4-servo controller.

19019 dec. = 4A4Bh
4A4Bh x 3 pole pairs = DEE1h
DEE1h = 57057 dec.

If the value exceeds 65535 dec., the lower 16 bit of the hexadecimal result must be entered.

Example 2:

6-pole motor (3 pole pairs) has a system position of 23497 dec. with a S4-servo controller.

23497 dec. = 5BC9h
5BC9h x 3 pole pairs = 1135Bh
1135Bh = 70491 dec.
135Bh = 4955 dec.

CP.21 Rotation change

Value	Setting	Function	Description
Encoder rotation			The speed display at CP.1 must be positive when the engine runs manual in clockwise direction. The signals SIN+ and SIN- of the resolver have to be changed, if the sign is wrong. Please ensure that the signals are not short-circuited with the internal shield (see connection resolver). The signals A(+) and A(-) must be changed for units with SIN/COS encoder. Should this involve too much effort then you can achieve a rotation reversal of encoder 1 by means of this parameter.
0	x	no change	
1		track exchanged	
Options			
0	x	no change	
2...15		reserved	
Encoder system			
0	x	no change	
16		inverted	

3.2.4 Special Adjustments

The following parameters serve for the optimization of the drive and the adaption to certain applications. These adjustments can be ignored at the initial start-up.

CP.22 Maximum speed

Co-domain	Setting	Description
0...4000 rpm	2100 rpm	In order to limit the setpoint value a maximum speed must be preset. This limit value is the basis for further setpoint calculations and for the determination of setpoint characteristics. The maximum speed limits the setpoint speed only. Because of speed ripples, speed overshoot or hardware defects (e.g. defective encoder) the actual speed may exceed these limits.

CP.23 Fixed speed 1 (input 1)

CP.24 Fixed speed 2 (input 2)

Co-domain	Setting	Description
CP.23 0...±4000 rpm	100 rpm	Two fixed speeds can be adjusted. The selection is made by the inputs I1 and I2. If adjustments are made that are outside the fixed limit of CP.22, then the speed is internally limited.
CP.24	-100 rpm	
 Input I1 + input I2 = fixed speed 3 (factory setting = 0 rpm) The Step speed 3 cannot adjusted in the CP-mode.		

CP.25 Acceleration time

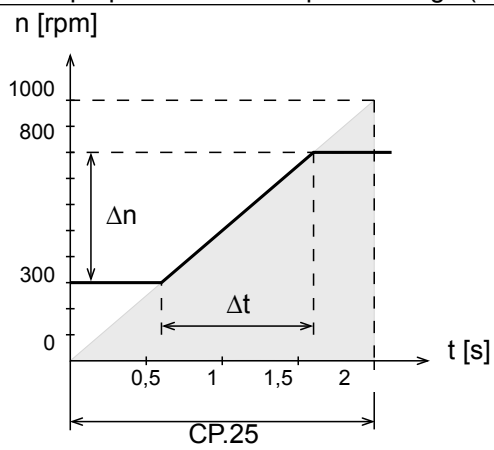
Co-domain	Setting	Description
0.00...300.00 s	5.00 s	Defines the time needed to accelerate from 0 to 1000 rpm. The actual acceleration time is proportional to the speed change (Δn).
Δn Speed change Δt Acceleration time for Δn		
Example		The drive should accelerate from 300 rpm auf 800 rpm in 1 s. $\Delta n = 800 \text{ rpm} - 300 \text{ rpm} = 500 \text{ rpm}$ $\Delta t = 1 \text{ s}$ $\text{CP.25} = \frac{\Delta t}{\Delta n} \times 1000 \text{ rpm} = \frac{1 \text{ s}}{500 \text{ rpm}} \times 1000 \text{ rpm} = 2 \text{ s}$

CP.26 Deceleration time

Co-domain	Setting	Description
-0.01...300.00 s	5.00 s	Defines the time needed to accelerate from 1000 to 0rpm. The actual deceleration time is proportional to the speed change (Δn). At a deceleration time of -1 the value from CP.25 is used (Display „=Acc“)!
Δn Speed change Δt Deceleration time for Δn		
	Example	<p>The drive should decelerate from 800 rpm to 300 rpm in 1 s.</p> <p>$\Delta n = 800 \text{ rpm} - 300 \text{ rpm} = 500 \text{ rpm}$ $\Delta t = 1 \text{ s}$</p> $\text{CP.26} = \frac{\Delta t}{\Delta n} \times 1000 \text{ rpm} = \frac{1 \text{ s}}{500 \text{ rpm}} \times 1000 \text{ rpm} = 2 \text{ s}$

GB

CP.27 S-curve time

Co-domain	Setting	Description
0.00 (off)...5.00 s	0.00 s (off)	For some applications it is of advantage when the drive starts and stops jerk-free. This is achieved through a straightening of the acceleration and deceleration ramps. The straightening time, also called S-curve time, can be adjusted with CP.27.
t_1 S-curve time (CP.27) t_2 Acceleration time (CP.25) t_3 Deceleration time (CP.26)		
	In order to drive defined ramps with activated S-curve time, the acceleration and deceleration times (CP.25 and CP.26) must be adjusted higher than the S-curve time (CP.27).	

Parameter description

CP.28 Torque reference source

Value	Source	Setting range	Description
0	AN1+ / AN1-	0 %...±100 % = 0...±CP.29	With this parameter the required setpoint source for torque control can be adjusted.
1	AN2+ / AN2-	0 %...±100 % = 0...±CP.29	
2	digital absolute	CP.29	
3...5	only application mode		
The values must be confirm by „ENTER“.			

CP.29 Absolute torque reference

Co-domain	Setting	Description
±10000.00 Nm	see 3.3	The absolute torque reference of the drive is adjusted with parameter CP.29 in torque controlled operation (CP.10 = 5) and with digital setpoint setting (CP.28 = 2). The sign stands for direction of rotation to be active. In speed controlled operation (CP.10 = 4) the parameter works as torque limit in all quadrants. The sign has no effect at that. The factory setting depends on the unit size (see 3.3 „Factory Settings“). During controlled operation (CP....10) this parameter has no function.
		Because of normal type differences and temperature deviations of the motors, tolerances of up to 30% are possible in the base speed range (see reference on page 13).

CP.30 KP speed

Co-domain	Setting	Description
0...32767	300	The proportional factor of the speed controller is adjusted in these parameters (see chapter 5 „Start-up“).

CP.31 KI speed

Co-domain	Setting	Description
0...32767	100	The integral factor of the speed controller is adjusted in these parameters (see chapter 5 „Start-up“).

CP.32 Switching frequency

Co-domain	Setting	Description
2 / 4 / 8 / 12 / 16 kHz	dependend of the power circuit	The switching frequency with which the power modules are clocked can be changed depending on the application. The employed power stage determines the maximum switching frequency as well as the factory setting (see manual:part 2). The values must be confirm by „ENTER“.
Refer to following list to learn about influences and effects of the switching frequency.	low switching frequency	
	less inverter heating	high switching frequency
	less discharge current	less noise development
	less switching losses	improved sine-wave simulation
	less radio interferences	less motor losses
	improved controller characteristics	
	improved concentricity with low speed (only open loop!)	
	At switching frequencies above 4 kHz pay absolute attention to the max. motor line length in the technical data of the power circuit manual (Part 2).	

CP.33 Relay output 1 / function

CP.34 Relay output 2 / function

CP.33 and CP.34 determine the function of the two relay outputs (terminals X2A.24...26 and X2A.27...29). The values must be confirm by „ENTER“.

Value	Function
0	No function (generally off)
1	Generally on
2	Run signal; also by DC-braking
3	Ready signal (no error)
4	Fault relay
5	Fault relay (not at under voltage error)
6	Warning or error message at abnormal stopping
7	Overload alert signal
8	Overtemperature alert signal power modules
9	External overtemperature alert signal motor
10	Only application mode
11	Overtemperature alert signal interior OHI
12...19	Only application mode
20	Actual value = set value (CP.3 = Fcon; rcon; not at noP, LS, error, SSF)
21	Accelerate (CP.3 = FAcc, rAcc, LAS)
22	Decelerate (CP.3 = FdEc, rdEc, LdS)
23	Real direction of rotation = set direction of rotation
24	Utilization > switching level ¹⁾
25	Active current > switching level ¹⁾
26	Only application mode
27	Real value (CP.1) > switching level ¹⁾
28	Setpoint (CP.2) > switching level ¹⁾
29...30	Only application mode
31	Absolute setpoint at AN1 > switching level ¹⁾
32	Absolute setpoint at AN2 > switching level ¹⁾
33	Only application mode
34	Setpoint at AN1 > switching level ¹⁾
35	Setpoint at AN2 > switching level ¹⁾
36...39	Only application mode
40	Hardware current limit activated
41	Modulation on-signal
42...46	Only application mode
47	Ramp output value > switching level ¹⁾
48	Apparent current (CP.4) > switching level ¹⁾
49	Forward running (not at noP, LS, abnormal stopping or error)
50	Reverse running (not at noP, LS, abnormal stopping or error)
51	Warning E.OL2
52	Current regulator limit reached
53	Speed regulator limit reached
54...62	Only application mode
63	Absolute value ANOUT1 > switching level ¹⁾
64	Absolute value ANOUT2 > switching level ¹⁾
65	ANOUT1 > switching level ¹⁾
66	ANOUT2 > switching level ¹⁾
67...69	Only application mode
70	Driving current active (safety relay)
71...72	Only application mode
73	Absolut active power > switching level ¹⁾
74	Active power > switching level ¹⁾
75...79	Only application mode
80	Active current > switching level ¹⁾
	further on next side

Parameter description

Value	Function
81	Real value channel 1 > switching level ¹⁾
82	Real value channel 2 > switching level ¹⁾
83	HSP5 bus synchronized
84	Only application mode

1) Switching level of CP.33 = 100; switching level of CP.34 = 4

CP.35 Limit switch / stopping mode

This parameter determines the reaction of the drive, to terminal X2A.14 (F) and/or X2A.15 (R). These terminals are programmed as limit switches. The reaction of the drive is shown in the table below.

Value	Setting	Display	Reaction	Restart
0		E.PR _x	Immediate disabling of modulation	Remove fault, reset
1		A.PR _x	Quick stopping / disabling of modulation after reaching speed 0	
2		A.PR _x	Quick stopping / holding torque at speed 0	
3		A.PR _x	Immediate disabling of modulation	Autoreset, if no fault is present
4		A.PR _x	Quick stopping / disabling of modulation after reaching speed 0	
5		A.PR _x	Quick stopping / holding torque at speed 0	
6	x	—	No effect to the drive, fault is ignored!	—

CP.36 Reaction to external fault

With the external error monitoring external units can take direct influence on the drive. This parameter determines the response of the drive to a signal at terminal X2A.12 (I3) according to following table.

Value	Setting	Display	Reaction	Restart
0	x	E.PR _x	Immediate disabling of modulation	Remove fault, reset
1		A.PR _x	Quick stopping / disabling of modulation after reaching speed 0	
2		A.PR _x	Quick stopping / holding torque at speed 0	
3		A.PR _x	Immediate disabling of modulation	Autoreset, if no fault is present
4		A.PR _x	Quick stopping / disabling of modulation after reaching speed 0	
5		A.PR _x	Quick stopping / holding torque at speed 0	
6		—	No effect to the drive, fault is ignored!	—

Operation of the Unit

3.3 Motor data (factory setting)

The following table contains the motor data of standard motors.

Parameter		CP.11	CP.12	CP.13	CP.14	CP.15	CP.16	CP.17	CP.18	CP.29
Unit size/ voltage class	Default motor	Rated motor torque	Rated motor speed	Rated motor frequency	Rated motor current	DSM EMK voltage constant	DSM winding inductance	DSM winding resistance	Stand still current	Maximum torque
		[Nm]	[rpm]	[Hz]	[A]	[V/1000rpm]	mH	Ω	[A]	[Nm]
09/200V	C3.SM.000-3200	3,9	3000	150	4,20	69	6,9	2,0	5,1	22,09
10/200V	C4.SM.000-3200	5	3000	150	5,7	68	4,5	1,2	7,1	30,68
12/200V	D2.SM.000-3200	6,1	3000	150	8,1	67	4	1	8,5	53,53
13/200V	D3.SM.000-3200	8,4	3000	150	10,9	69	2,8	0,6	12,4	69,92
14/200V	E4.SM.000-3200	15,5	3000	150	16	89	1,3	0,29	27,8	93,40
09/400V	C3.SM.000-3400	3,9	3000	150	2,4	118	20,6	5,9	2,9	22,47
10/400V	C4.SM.000-3400	5	3000	150	3,4	113	13,1	3,4	4,2	30,81
12/400V	D2.SM.000-3400	6,1	3000	150	4,5	119	12,8	3,2	4,8	53,21
13/400V	D4.SM.000.3400	9,9	3000	150	7,3	121	1,5	1,4	8,5	73,26
14/400V	E2.SM.000-3400	11	3000	150	7	136	8,2	2	9	80,12
15/400V	E4.SM.000-3400	15,5	3000	150	9,9	143	3,4	0,81	17,3	118,83
16/400V	F1.SM.000-3400	20	1465	150	13,8	130	7	0,58	17	165,99
17/400V	F2.SM.000-3400	31	3000	150	20,6	135	3,6	0,23	32,2	213,37
18/400V	F3.SM.000-3400	33	3000	150	22,9	131	1,7	0,13	46,2	253,27

3.4 The drive mode

The Drive Mode is an operating mode of KEB COMBIVERT that permits the manual starting of the drive by the operator. After switching the control release the set value and rotation setting are effected exclusively over the keyboard. In order to activate the drive mode the corresponding password (see last but one page) must be entered in CP. 0. The display switches over as follows:

Direction of rotation
 F = clockwise rotation
 r = counter clockwise rotation

Status
 noP = no control release
 LS = neutral position

3.4.1 Start/stop drive

Modulation blocked Drive not controlled **F LS** Drive decreases to 0 rpm and switches the modulation off



Drive accelerates onto the adjusted set value **F 500** Drive operates with adjusted set value

3.4.2 Changing the direction of rotation



Drive changes direction of rotation

r 500

3.4.3 Presetting the setpoint



Display changes when key is pressed to set value display/presetting



500

Set value can be changed with UP/DOWN at pressed FUNC/SPEED key

3.4.4 Leaving the drive mode

To exit the drive mode the inverter must be in status "stop" (Display noP or LS). Press the FUNC and ENTER keys simultaneously for about 3 seconds to leave the drive mode. The CP-parameters appear in the display.



+



for 3 seconds

4. Error Assistance

At KEB COMBIVERT error messages are always represented with an "E." and the appropriate error in the display. Error messages cause the immediate deactivation of the modulation. Restart possible only after reset or autoreset.

Malfunction are represented with an „A.“ and the appropriate message. Reactions to malfunctions can vary. In the following the display and their cause are described.

GB

Display	COMBIVIS		Meaning
Status Messages			
bbL	base block	76	Power modules for motor de-excitation locked
bon	close brake	85	Brake control, brake engaged (see chapter 6.9)
boFF	open brake	86	Brake control, brake released (see chapter 6.9)
Cdd	calculate drive	82	Measurement of the motor stator resistance.
dcb	DC brake	75	Motor is decelerated by a DC-voltage at the output.
dLS	low speed / DC brake	77	Modulation is switched off after DC-braking (see chapter 6.9 "DC-Braking").
FAcc	forward acceleration	64	Acceleration with the adjusted ramps in clockwise direction of rotation.
Fcon	forward constant	66	Acceleration / deceleration phase is completed and it is driven with constant speed / frequency in clockwise direction of rotation.
FdEc	forward deceleration	65	It is stopped with the adjusted ramp times in clockwise direction of rotation.
HCL	hardware current limit	80	The message is output if the output current reaches the hardware current limit.
LAS	LA stop	72	This message is displayed if during acceleration the load is limited to the adjusted load level.
LdS	Ld stop	73	This message is displayed if during deceleration the load is limited to the adjusted load level or the DC-link current to the adjusted voltage level.
LS	low speed	70	No direction of rotation pre-set, modulation is off.
nO_PU	power unit not ready	13	Power circuit not ready or not identified by the control.
noP	no operation	0	Control release (terminal ST) is not switched.
PA	positioning active	122	This message is displayed during a positioning process.
PLS	low speed / power off	84	No modulation after Power-Off.
PnA	position not reachable	123	The specified position cannot be reached within the pre-set ramps. The abort of the positioning can be programmed.
POFF	power off function	78	Depending on the programming of the function (see chapter 6.9 „Power-off Function“) the inverter restarts automatically upon system recovery or after a reset.
POSI	positioning	83	Positioning function active (F5-G).
rAcc	reverse acceleration	67	Acceleration with the adjusted ramp times in anti-clockwise direction of rotation.
rcon	reverse constant	69	Acceleration / deceleration phase is completed and it is driven with constant speed / frequency in clockwise direction of rotation.
rdEc	reverse deceleration	68	It is stopped with the adjusted ramp times in anti-clockwise direction of rotation.
rFP	ready for positioning	121	The drive signals that it is ready to start the positioning process.
SLL	stall	71	This message is displayed if during constant operation the load is limited to the adjusted current limit.
SrA	search for ref. active	81	Search for reference point approach active.
SSF	speed search	74	Speed search function active, that means that the inverter attempts to synchronize onto a running down motor.
STOP	quick stop	79	The message is output if as response to a warning signal the quick-stop function becomes active.

further on next side

Display	COMBIVIS		Meaning
Error Messages			
E. br	Error! brake	56	Error: can occur in the case of switched on brake control (see chapter 6.9.5), if the load is below the minimum load level (Pn.43) at start up or the absence of an engine phase was detected the load is too high and the hardware current limit is reached
E.buS	Error! Watchdog	18	Adjusted monitoring time (Watchdog) of communication between operator and PC / operator and inverter has been exceeded.
E.Cdd	Error! calc. drive data	60	Error: During the automatic motor stator resistance measurement.
E.co1	Error! counter overrun 1	54	Counter overflow encoder channel 1.
E.co2	Error! counter overrun 2	55	Counter overflow encoder channel 2.
E.dOH	Error! drive overheat	9	Error: Overtemperature of motor PTC. Error can only be reset at E.ndOH, if PTC is again low-resistance. Causes: resistance at the terminals T1/T2 >1650 Ohm motor overloaded line breakage to the temperature sensor
E.dri	Error! driver relay	51	Error: Driver relay. Relay for driver voltage on power circuit has not picked up even though control release was given.
E.EEP	Error! EEPROM defective t	21	After reset the operation is again possible (without storage in the EEPROM)
E. EF	Error! external fault	31	Error: External error. Is triggered, if a digital input is being programmed as external error input and trips.
E.EnC	Error! Encoder cable	32	Cable breakage at the resolver or incremental encoder
E.Hyb	Error! hybrid	52	Invalid encoder interface identifier.
E.HybC	Error! hybrid changed	59	Error: Encoder interface identifier has changed, it must be confirmed over ec.0 or ec.10.
E.iEd	Error! input error detect	53	Hardware failure at the NPN/PNP change-over or at the start/stop measurement.
E.Inl	Error! initialisation MFC	57	MFC not booted.
E.LSF	Error! load shunt fault	15	Load-shunt relay has not picked up. occurs for a short time during the switch-on phase, but must automatically be reset immediately. If the error message remains the following causes may be applicable: load-shunt defective input voltage wrong or too low high losses in the supply cable braking resistor wrongly connected or damaged braking module defective
E.ndOH	no ERROR drive overheat	11	Motor temperature switch or PTC at the terminals T1/T2 is again in the normal operating range. The error can be reset now.
E.nOH	no E. over heat pow.mod.	36	Temperature of the heat sink is again in the permissible operating range. The error can be reset now.
E.nOHI	no ERROR overheat int.	7	No longer overheating in the interior E.OHI, interior temperature has fallen by at least 3°C
E.nOL	no ERROR overload	17	No more overload, OL-counter has reached 0%; after the error E.OL a cooling phase must elapse. This message appears upon completion of the cooling phase. The error can be reset now. The inverter must remain switched on during the cooling phase.
E.nOL2	no ERROR overload 2	20	The cooling time has elapsed. The error can be reset.

further on next side

Error Assistance

Display	COMBIVIS		Meaning
E. OC	Error! overcurrent	4	Occurs, if the specified peak current is exceeded. Causes:
			acceleration ramps too short
			the load is too big at turned off acceleration stop and turned off constant current limit
			short-circuit at the output
			short-circuit at the output
			deceleration ramp too short
			motor cable too long
			EMC
			DC brake at high ratings active (see 6.9.3)
E. OH	Error! overheat pow.mod.	8	Error: Overtemperature of power module. Error can only be reset at E.nOH. Causes:
			insufficient air flow at the heat sink (soiled)
			ambient temperature too high
			ventilator clogged
E.OH2	Error! motor protection	30	Electronic motor protective relay has tripped.
E.OHI	Error! overheat internal	6	Error: Overheating in the interior: error can only be reset at E.nOHI, if the interior temperature has dropped by at least 3 °C.
E. OL	Error! overload (lxt)	16	Error: Overload error can only be reset at E.nOL, if OL-counter reaches 0% again. Occurs, if an excessive load is applied longer than for the permissible time (see technical data). Causes:
			poor control adjustment (overshooting)
			mechanical fault or overload in the application
			inverter not correctly dimensioned
			motor wrongly wired
			encoder damaged
E.OL2	Error! overload 2	19	Occurs if the standstill constant current is exceeded (see technical data and overload characteristics). The error can only be reset if the cooling time has elapsed and E.nOL2 is displayed.
E. OP	Error! Overvoltage	1	Voltage in the DC-link circuit too high. Occurs when the DC bus voltage rises above the permissible value. Causes:
			poor controller adjustment (overshooting)
			input voltage too high
			interference voltages at the input
			deceleration ramp too short
			braking resistor defective or too small
E.OS	Error! over speed	58	Real speed is bigger than the max. output speed.
E.PFC	Error! Power factor control	33	Error in the power factor control
E.PrF	Error! prot. rot. for.	46	The drive has driven onto the right limit switch. Programmed response „Error, restart after reset” (see chapter 6.7 „Response to errors or warning messages”).
E.Prr	Error! prot. rot. rev.	47	The drive has driven onto the left limit switch. Programmed response „Error, restart after reset” (see chapter 6.7 „Response to errors or warning messages”).
E. Pu	Error! power unit	12	Error: General power circuit fault
E.Puci	Error! Unknown power unit	49	Error: During the initialization the power circuit could not be recognized or was identified as invalid.
			further on next side

Display	COMBIVIS		Meaning
E.Puch	Error! power unit changed	50	Error: Power circuit identification was changed; with a valid power circuit this error can be reset by writing to SY.3. If the value displayed in SY.3 is written, only the power-circuit dependent parameters are reinitialized. If any other value is written, then the default set is loaded. On some systems after writing Sy.3 a Power-On-Reset is necessary.
E.PUCO	Error! Power unit communication	22	Error: Parameter value could not be written to the power circuit. Acknowledgement from LT <> OK
E.PUIN	Error! Power unit invalid	14	Error: Software version for power circuit and control card are different. Error cannot be reset (only at F5-G B-housing)
E.SbuS	Error! bus synchron	23	Synchronization over sercos-bus not possible. Programmed response „Error, restart after reset”.
E.SEt	Error! set	39	It has been attempted to select a locked parameter set. Programmed response „Error, restart after reset”.
E.SLF	Error! Software limit switch forward	44	The target position lies outside of the limit defined with the right software limit switch. Programmed response „Error, restart after reset”.
E.SLr	Error! Software limit switch reverse	45	The target position lies outside of the limit defined with the left software limit switch. Programmed response „Error, restart after reset”.
E. UP	Error! underpotential	2	Error: Undervoltage (DC-link circuit) Occurs, if DC-link voltage falls below the permissible value. Causes:
			input voltage too low or instable
			inverter rating too small
			voltage losses through wrong cabling
			the supply voltage through generator / transformer breaks down at very short ramps
			at F5-G housing B E.UP is also displayed if no communication takes place between power circuit and control card.
E.UPh	Error! Phase failure	3	One phase of the input voltage is missing (ripple-detection)
Warning Messages			
A.buS	Warning! Watchdog	93	Warning: Watchdog for communication between operator/control card or operator/PC has responded. The response to this warning can be programmed.
A.dOH	Warning! drive overheat	96	The motor temperature has exceeded an adjustable warning level. The switch off time is started. The response to this warning can be programmed. This warning can be generated only with a special power circuit.
A. EF	Warning! external fault	90	This warning is triggered via an external input. The response to this warning can be programmed.
A.ndOH	All-clear! drive overheat	91	The motor temperature is again below the adjusted warning level. The switch off time is stopped.
A.nOH	All-clear! overheat pow.mod.	88	The heat sink temperature is again below the adjusted warning level.
A.nOHI	All-clear! overheat internal	92	The temperature in the interior of the inverter is again below the warning threshold.
A.nOL	All-clear! overload	98	OL counter has reached 0 %, the warning “overload“ can be reset.
A.nOL2	All-clear! overload 2	101	The cooling time after “Warning! Overload during standstill“ has elapsed. The warning message can be reset.
A. OH	Warning! overheat pow.mod.	89	A level can be defined, when it is exceeded this warning is output. The response to this warning can be programmed.

further on next side

Error Assistance

Display	COMBIVIS		Meaning
A.OH2	Warning! motor protection	97	Warning: electronic motor protective relay has tripped. The response to this warning can be programmed.
A.OHI	Warning! overheat internal	87	The temperature in the interior of the inverter lies above the permissible level. The switch off time was started. The programmed response to this warning message is executed.
A. OL	Warning! overload	99	A level between 0 and 100 % of the load counter can be adjusted, when it is exceeded this warning is output. The response to this warning can be programmed.
A.OL2	Warning! overload 2	100	The warning is output when the standstill continuous current is exceeded (see technical data and overload characteristics). The response to this warning can be programmed. The warning message can only be reset after the cooling time has elapsed and A.nOL2 is displayed.
A.PrF	Warning! prot. rot. for.	94	The drive has driven onto the right limit switch. The response to this warning can be programmed.
A.Prr	Warning! prot. rot. rev.	95	The drive has driven onto the left limit switch. The response to this warning can be programmed.
A.SbuS	Warning! synchron	103	Synchronization over sercos-bus not possible. The response to this warning can be programmed.
A.SET	Warning! set	102	It has been attempted to select a locked parameter set. The response to this warning can be programmed.
A.SLF	Warning! Software limit switch forward	104	The target position lies outside of the limit defined with the right software limit switch. The response to this warning can be programmed.
A.SLr	Warning! Software limit switch reverse	105	The target position lies outside of the limit defined with the left software limit switch. The response to this warning can be programmed.

GB

5. Initial Start-up

The speed controller must be adjusted when the KEB COMBIVERT F5-SERVO is taken into operation. By using the software COMBIVIS a setvalue jump can be recorded. With the examples on the following page the speed controller can be adjusted.

- Install COMBIVIS on the PC and startup. Select and startup the programm SCOPE.
- Parameterize SCOPE:

Operating mode:	Offline
Time reference:	2ms
Trigger position:	5%
Trigger condition:	Fixed speed input
Channel A:	ru.01 Set speed
Channel B:	ru.07 Actual speed

- Go in the operating mode of SCOPE, calibrate channels and adjust time reference (e.g. 50ms/DIV).
- Switch control release X2A.16
- Preset fixed speed (e.g.: 50% nominal)
- Activate a fixed speed with an programmable input, the KEB COMBIVERT executes a setpoint step change.
- Subsequently the data are read out with the aid of SCOPE and compare recorded step change with the examples on the following page and adjust speed controller.
- Repeat step change and record again until a satisfying initial response and an optimal controller adjustment is found.

Rough adjustment of the speed controller without using the SCOPE:

- Increase P-part to the stability limit (system starts to oscillate) and then decrease by 30%.
- Repeat the same procedure with the I-part

6. Adjustment Speed Controller

With the PC software KEB COMBIVIS (Scope) set and real speed can be displayed. If one of the following real speed curves occurs at acceleration, the speed controller (CP.30, CP.31) should be adjusted according to the notes.

Problem	Very long transient process	Problem	Very long speed overshoot
Solution	Increase KP speed (CP.30); eventually reduce KI speed (CP.31)	Solution	Increase KP speed (CP.30); eventually reduce KI speed (CP.31)
Problem	Sustained oscillation short billowy, noises, vibes	Problem	Transient too slow / remaining system deviation
Solution	Decrease KP speed (CP.30)	Solution	Increase KI speed (CP.31)
Problem	Overshoot too long, strong speed decreases at load change	Problem	Sustained oscillation long billowy
Solution	Increase KI speed (CP.31)	Solution	Reduce KI speed (CP.31) and / or reduce KP speed (CP.30)

GB

7. Quick Reference

Displ.	Parameter	Setting range	Resolution	↵	Customer setting
CP.00	Password Input	0...9999	1	-	
CP.01	Encoder 1 speed	±4000 rpm	0.125 rpm	-	
CP.02	Setpoint display	±4000 rpm	0.125 rpm	-	
CP.03	Inverter state	0...255	1	-	
CP.04	Apparent current	0...6553.5A	0.1 A	-	
CP.05	Peak apparent current	0...6553.5A	0.1 A	-	
CP.06	Actual torque	±10000.00 Nm	0.01 Nm	-	
CP.07	Actual DC voltage	0...1000V	1V	-	
CP.08	Peak DC voltage	0...1000V	1V	-	
CP.09	Output voltage	0...778 V	1V	-	
CP.10	Speed control configuration	4...5	1	-	
CP.11	DSM rated torque	0.1...6553.5A	0.1 Nm	-	
CP.12	DSM rated speed	0...32000 rpm	1 rpm	-	
CP.13	DSM rated frequency	0.0...1600.0Hz	0.1 Hz	-	
CP.14	DSM rated current	0.0...710.0 A	0.1 A	-	
CP.15	DSM EMK voltage constant	0...1000V	1V	-	
CP.16	DSM winding inductance	0.01...500.00mH	0.01 mH	-	
CP.17	DSM winding resistance	0.000...50.000 Ω	0.001 Ω	-	
CP.18	DSM current for zero speed	0.0...700.0A	0.1 A	-	
CP.19	Load motor dependent parameter	1...2	1	E	
CP.20	System position	0...65535	1	-	
CP.21	Rotation change	0...19	1	-	
CP.22	Maximum speed	0...4000rpm	0.125 rpm	-	
CP.23	Fixed Speed 1	±4000 rpm	0.125 rpm	-	
CP.24	Fixed speed 2	±4000 rpm	0.125 rpm	-	
CP.25	Acceleration time	0.00...300.00 s	0.01 s	-	
CP.26	Deceleration time	-0.01...300.00 s	0.01 s	-	
CP.27	S-curve time	0.00...5.00 s	0.01 s	-	
CP.28	Torque reference source	0...5	1	E	
CP.29	Absolute torque reference	±10000.00 Nm	0,01 Nm	-	
CP.30	KP speed	0...32767	1	-	
CP.31	KI speed	0...32767	1	-	
CP.32	Switching frequency	2/4/8/12/16kHz	-	E	
CP.33	Relay output 1 / Function	0...84	1	E	
CP.34	Relay output 2 / Function	0...84	1	E	
CP.35	Reaction to limit switch	0...6	1	-	
CP.36	Reaction to external fault	0...6	1	-	

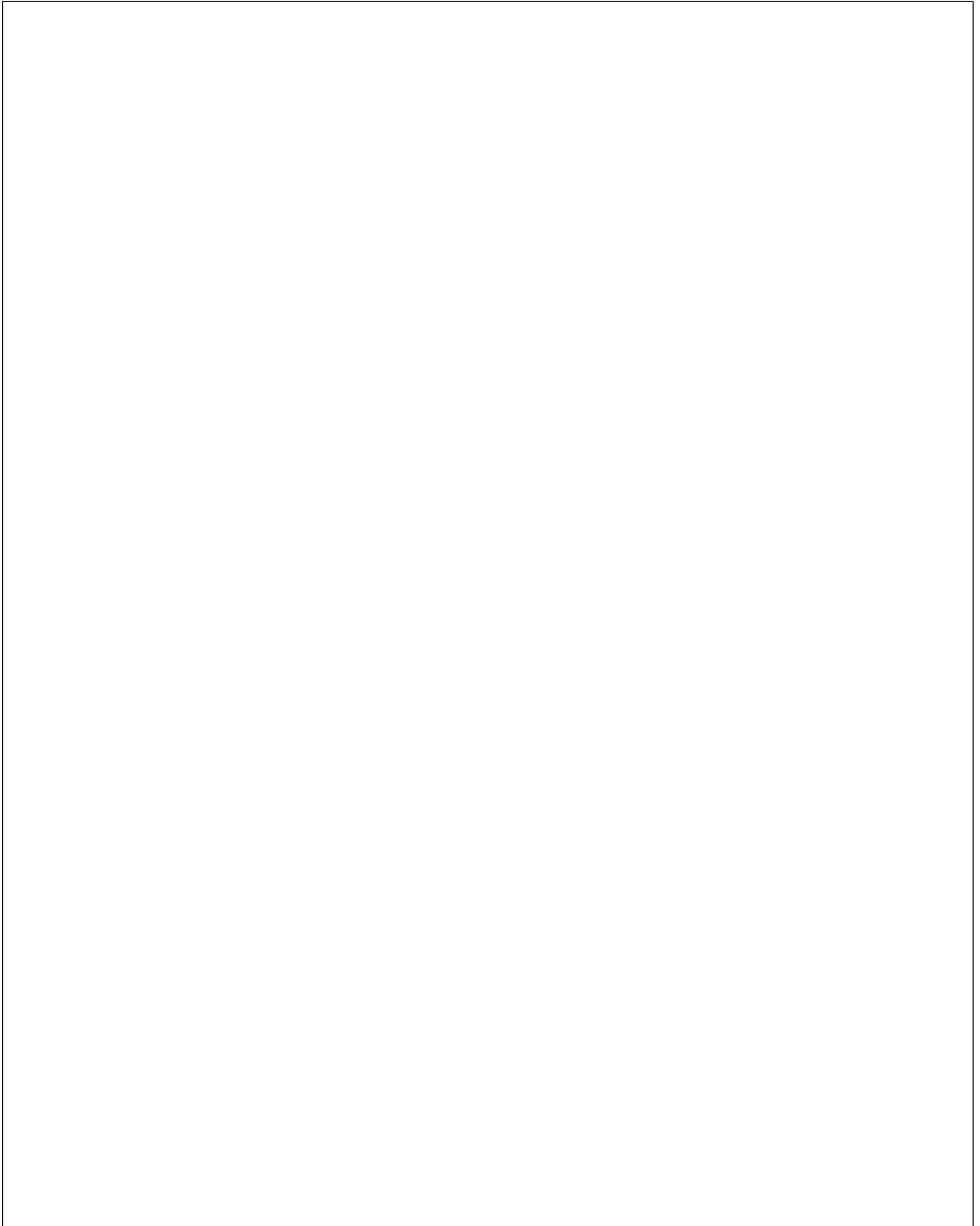

GB

8. Passwords

Read only	Read/Write	Drive mode
100	200	500

GB



Karl E. Brinkmann GmbH
Försterweg 36-38 • D-32683 Barntrup
fon: +49 5263 401-0 • fax: +49 5263 401-116
net: www.keb.de • mail: info@keb.de

KEB Antriebstechnik GmbH & Co. KG
Wildbacher Str. 5 • D-08289 Schneeberg
fon: +49 3772 67-0 • fax: +49 3772 67-281
mail: info@keb-combidrive.de

KEB Antriebstechnik Austria GmbH
Ritzstraße 8 • A-4614 Marchtrenk
fon: +43 7243 53586-0 • fax: +43 7243 53586-21
net: www.keb.at • mail: info@keb.at

KEB Antriebstechnik
Herenveld 2 • B-9500 Geraadsbergen
fon: +32 5443 7860 • fax: +32 5443 7898
mail: vb.belgien@keb.de

KEB CHINA Karl E. Brinkmann GmH
(Xinmao Building, Caohejing Development Zone)
No. 99 Tianzhou Road (No.9 building, Room 708)
CHN-200233 Shanghai, PR. China
fon: +86 21 54503230-3232 • fax: +86 21 54450115
net: www.keb.cn • mail: info@keb.cn

KEB CHINA Karl E. Brinkmann GmH
No. 36 Xiaoyun Road • Chaoyang District
CHN-10027 Beijing, PR. China
fon: +86 10 84475815 + 819 • fax: +86 10 84475868
net: www.keb.cn • mail: hotline@keb.cn

KEB Antriebstechnik Austria GmbH
Organizační složka
K. Weise 1675/5 • CZ-370 04 České Budějovice
fon: +420 387 699 111 • fax: +420 387 699 119
net: www.keb.cz • mail: info.keb@seznam.cz

KEB España
C/ Mitjer, Nave 8 - Pol. Ind. LA MASIA
E-08798 Sant Cugat Sesgarrigues (Barcelona)
fon: +34 93 897 0268 • fax: +34 93 899 2035
mail: vb.espana@keb.de

Société Française KEB
Z.I. de la Croix St. Nicolas • 14, rue Gustave Eiffel
F-94510 LA QUEUE EN BRIE
fon: +33 1 49620101 • fax: +33 1 45767495
net: www.keb.fr • mail: info@keb.fr

KEB (UK) Ltd.
6 Chieftain Business Park, Morris Close
Park Farm, Wellingborough GB-Northants, NN8 6 XF
fon: +44 1933 402220 • fax: +44 1933 400724
net: www.keb-uk.co.uk • mail: info@keb-uk.co.uk

KEB Italia S.r.l.
Via Newton, 2 • I-20019 Settimo Milanese (Milano)
fon: +39 02 33500782 • fax: +39 02 33500790
net: www.keb.it • mail: kebitalia@keb.it

KEB - YAMAKYU Ltd.
15-16, 2-Chome, Takanawa Minato-ku
J-Tokyo 108-0074
fon: +81 33 445-8515 • fax: +81 33 445-8215
mail: info@keb.jp

KEB Nederland
Leidsevaart 126 • NL-2013 HD Haarlem
fon: +31 23 5320049 • fax: +31 23 5322260
mail: vb.nederland@keb.de

KEB Polska
ul. Budapesztańska 3/16 • PL-80-288 Gdańsk
fon: +48 58 524 0518 • fax: +48 58 524 0519
mail: vb.polska@keb.de

KEB Portugal
Avenida da Igreja – Pavilhão A n.º 261 Mouquim
P-4770 - 360 MOUQUIM V.N.F.
fon: +351 252 371318 + 19 • fax: +351 252 371320
mail: keb.portugal@netc.pt

KEB Taiwan Ltd.
No.8, Lane 89, Sec.3; Taichung Kang Rd.
R.O.C.-Taichung City / Taiwan
fon: +886 4 23506488 • fax: +886 4 23501403
mail: info@keb.com.tw

KEB Korea Seoul
Room 1709, 415 Missy 2000
725 Su Seo Dong, Gang Nam Gu
ROK-135-757 Seoul/South Korea
fon: +82 2 6253 6771 • fax: +82 2 6253 6770
mail: vb.korea@keb.de

KEB Sverige
Box 265 (Bergavägen 19)
S-43093 Hälsö
fon: +46 31 961520 • fax: +46 31 961124
mail: vb.schweden@keb.de

KEB America, Inc.
5100 Valley Industrial Blvd. South
USA-Shakopee, MN 55379
fon: +1 952 224-1400 • fax: +1 952 224-1499
net: www.kebamerica.com • mail: info@kebamerica.com